

Parts needed to mount the PK-4 extrusion



Mounting track (A)



Extrusion (B)



LED Strip (C)



End Cap (D)



Cover (E)



Protective foam (F)



Large end cap (G)

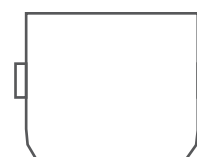

Mounting bracket (H)

Tools needed for mounting:

- mounting adhesive
- drill

NOTE! All LED strips must be connected to a 12 V or 24 V power supply.

IMPORTANT: The manual presents the simplest mounting procedure. More mounting procedures and related accessories can be found at klusdesign.com.

1. Drill a hole in the mounting track (A) and extrusion (B) in the same place to run the power wire.

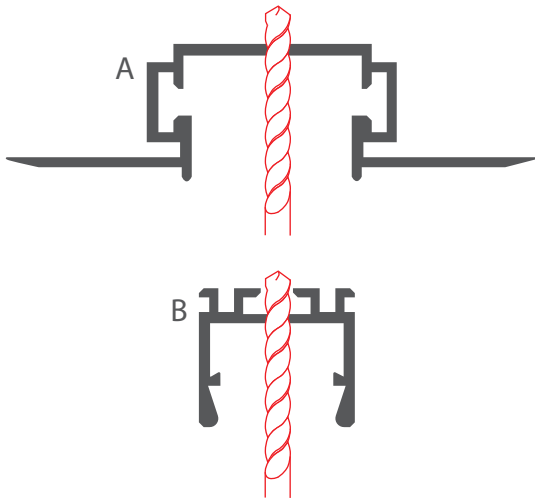

2. Mount the LED strip (C) inside the extrusion (B) run the power wire through the hole and mount the cover (E).

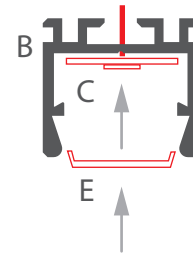

3. Place the mounting bracket (H) on the extrusion (B) Recommended 2 brackets per 3ft extrusion. Insert the end cap (D).

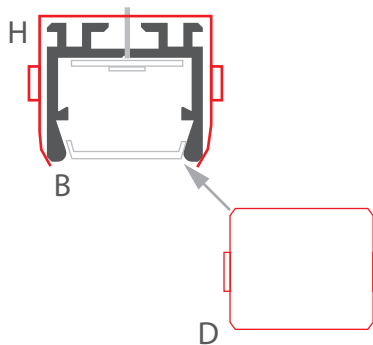

4. Insert the large end cap (G) into the mounting track (A).

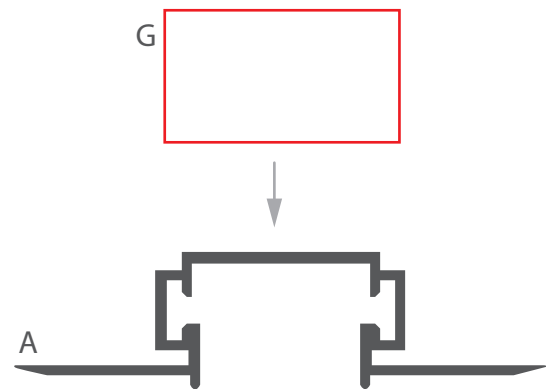

5. Glue the mounting track into the slot with adhesive, and run the power wire through the pre-drilled hole. Insert the protective foam (F) into the mounting track (A).

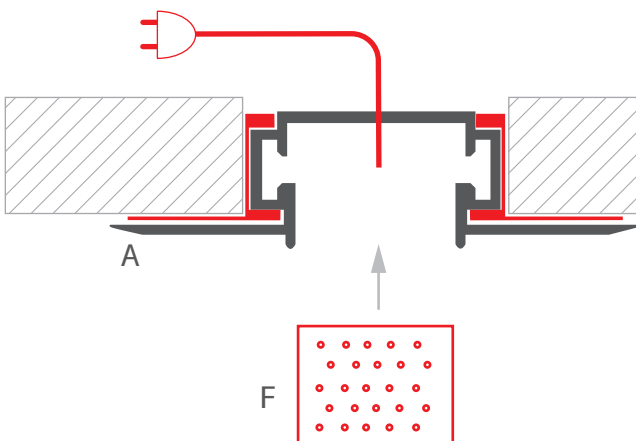

6. Apply a layer of plaster to the extrusion and surface and then paint the surface. The foam protects the inside of the mounting track during mudding, sanding etc.

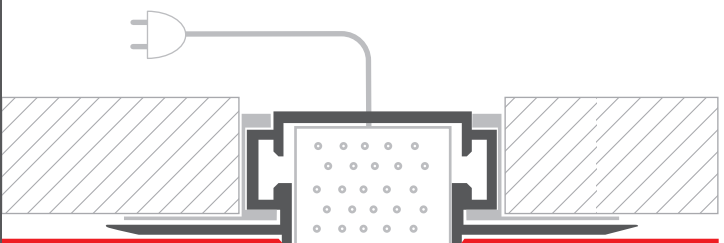

7. Remove the protective foam (F) once all painting is finished.

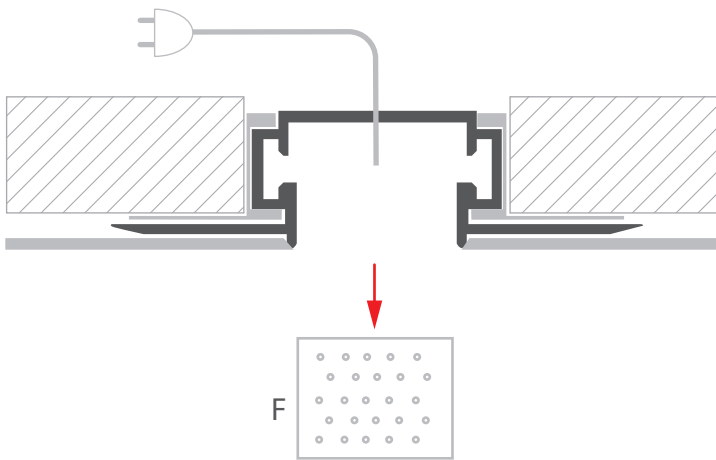

8. Connect the power wire and snap the fixture into the mounting track (A)

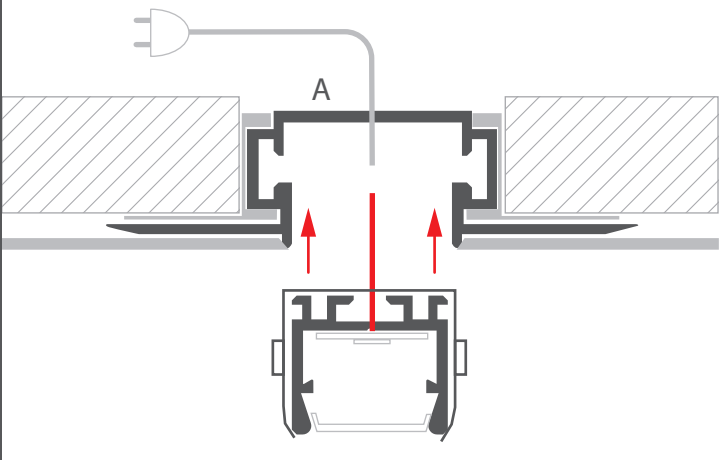

IMPORTANT! In order to disassemble the luminaire, use any two blades with a thickness of not more than 0.01". They should be inserted into the gaps between the mounting track and the extrusion on both sides of the mounting bracket.

Moving the blades in the direction of the bracket will cause the latches to buckle and release it from the mounting track. Repeat the procedure for all brackets.

